

# Millstones from Kale in Krševica (Southeastern Serbia)

*Petar Popović, Aleksandar Kapuran*  
Belgrade

## 1. Introduction

The site Kale is situated in the village Krševica about ten kilometers to the east of Bujanovac. The small-scale excavations in 1966<sup>1</sup> indicated that it is an outstanding site but large-scale excavations have been resumed only in 2001. Soon it became clear that substantial remains of the settlement covering around 4 hectares and dating from the end of Classical and the beginning of the Hellenistic period are lying on a dominant elevation above the Južna (South) Morava valley. Despite the fact that just small portion of the site has been investigated so far, it was possible, after the works carried out between 2001 and 2007, to gain general impression about the appearance of this relatively large and well organized settlement. Few building horizons with various structures creating the acropolis were encountered on the plateau. A complex with buildings and other structures that were protected by the rampart and broad trench with an earthen barrow existed on the central section of the plateau in the latest horizon. On the basis of many obtained data the largest part of the settlement was located on the smaller terraces on the northeastern slope descending towards the Krševica River valley<sup>2</sup>. At the foothill was discovered rather large complex with ramparts made of massive ashlars, stone platforms, building and many other structures that was identified as 'hydrotechnical complex' because of its specific purpose. The reason is that there are water springs at many spots in the lower layers so the excavations were possible only with the pumps to drain the water (Fig. 1). All this indicate that this important segment of the settlement was associated with the problem of supply and regulation of water<sup>3</sup>.

---

<sup>1</sup> Mikulčić/Jovanović 1968.

<sup>2</sup> Popović 2005, 145 ff; 2006, 523 ff.

<sup>3</sup> Popović 2007, 815.

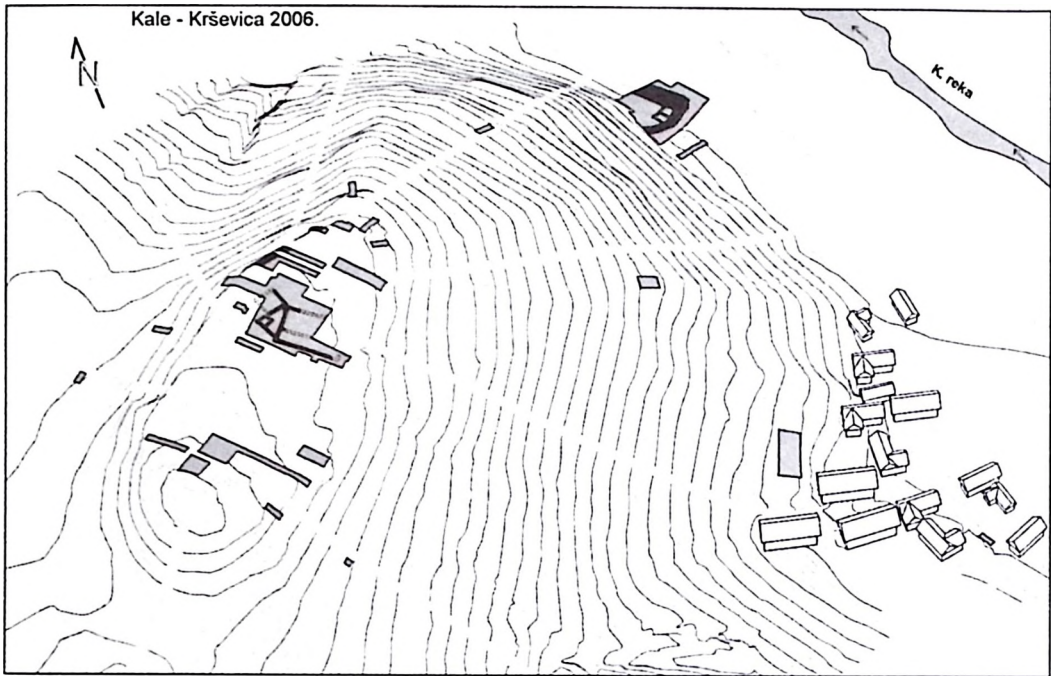

Fig. 1 Kale – Krševica, site plan 3D, 2006

Large amount of archaeological material was discovered in the course of excavations and worth mentioning are, first of all, the finds of imported pottery from the Attic and North Aegean workshops dating from the beginning of the 4<sup>th</sup> to the first decades of the 3<sup>rd</sup> century BC and this is the basic chronological framework for the life in this settlement<sup>4</sup>. By far the greatest amount of material, however, consists of local pottery made after the Greek models. This wide repertoire of shapes includes the tableware as well as various kitchenware, pots and pithoi of large size used for preparation or storing the food<sup>5</sup>. As in every organized settlement the sustenance of population was rather important so we will on this occasion pay attention to some finds from Krševica related to this aspect of everyday life of the inhabitants.

This concerns large quantity of mostly fragmented mills made of volcanic stone (lava) that have been discovered in an area from the acropolis to the suburbium and their main purpose was to grind wheat to provide flour for making bread. With just few exceptions one distinct type of mills was used but all of them are illustrating well the technological level of the inhabitants of this settlement in the 4<sup>th</sup> and in the first decades of the 3<sup>rd</sup> century BC.

<sup>4</sup> Popović 2005, 156 f; Krstić 2005.

<sup>5</sup> Antić/Babić 2005; Popović 2005, 157 f; Pl. II-III

## 2. Typology

Three main types were distinguished in the course of our investigation but one of them could be identified as the conspicuously prevailing type of mill.

*Type A.* This type consists of pounders and millstones of elongated shape with slightly concave working surface and they were used for grinding various grains (saddle quern). Besides many small fragments there were discovered also two better preserved specimens: pounder 7.6 x 9.8 cm in size, and at least two thirds of a millstone 19 cm long, 13.2 cm wide and 5.3 cm high (Pl. 1, 1-2). It has been found in the central zone of the acropolis in the surface layer, which is considerably damaged by soil cultivation. The mills of this type belong to the oldest forms known from the early prehistory. One specimen similar to our find is published recently on the cover of a book concerning the Neolithic ground stone industry in Serbia<sup>6</sup>. These finds could be related to the sporadic fragments of Late Bronze and Early Iron Age pottery discovered on the acropolis<sup>7</sup> but it is much more probable that they come from the thick layers of this settlement.

*Type B.* These mills consist of two blocks. The upper part is massive rectangular frame with two opposing shallow and broad grooves and with narrower grooves on the lateral sides. The interior segment has slanting 'V' shaped walls and long and narrow slit at the bottom. Second part is rectangular slab with working surface of corresponding size fixed into the ground (grinding platform). Considering their method of use they are identified as 'hopper rubber', 'pushing mill', 'hopper quern', or 'Olynthus mill'. For the best description we are quoting D. White: "The mill was worked by means of a wooden handle, which was placed across the top of the stone and held in place by two shallow slots cut into the rim at the two short ends. One end of the wooden handle was fixed to a pivot, while the other end was used as a lever to push the hopper back and forth over the grinding platform with a to-and-fro motion"<sup>8</sup>.

Around hundred smaller or larger fragments of mills have been discovered so far in the course of our investigation. They have been found in the trenches but also as the surface finds. The large number of specimens found on the acropolis is the result of relatively large investigated area with various structures but much of this material has been gathered particularly from the eroded slopes of the northeastern suburbium. The more conspicuous concentration of these objects has not been encountered in any particular area and it seems that mills were associated with the structures found within all sections of the site. Because of the intensive use and brittle stone texture they often cracked at more vulnerable spots usually in the middle where the grooves with slits are. The damaged pieces have been discarded

---

<sup>6</sup> Antonović 2003; cf. White 1963, 200 ff.

<sup>7</sup> Bulatović 2005.

<sup>8</sup> White 1963, 202 ff., Fig. 9; cf. Frankel 2003, 2 ff.

and sometimes used as building material (Fig. 2). Considering large number of identical or similar fragments we are presenting here just a small selection of best preserved and characteristic specimens, which could illustrate the finds from this site.



Fig. 2 Acropolis, fragment of millstone in the wall of northern building, 2003

The very first specimen from Krševica was discovered by chance during excavations in 1966<sup>9</sup>. The precise dimensions are not known but it is obvious that it is more of square than of rectangular shape (Pl. 1, 3). Second mill was discovered in 2003 on a slope at the foot of the site above the 'hydrotechnical' complex<sup>10</sup>. Both parts were lying near the smaller platform and they were obviously dislocated from the immediate vicinity. Upper part is, in contrast to other finds, made of sandstone and is not of completely symmetrical shape (instead of 36 x 32 cm, its size is 36 x 28 cm, the height is 10.4 cm and the dimensions of grooves are 7 x 1.6 cm and 5.6 x 1.6 cm). The slab (32 x 35 x 5-6 cm) was made of volcanic stone and on the working surface are conspicuous traces of arched striations (Pl. 1, 4 a-b). Other specimens are fragments of generally similar dimensions and of diverse quality of manufacture. Their widths vary from 30 to 35 cm but more precise lengths are impossible to establish. They are usually rather crudely worked pieces although there are

<sup>9</sup> Mikulčić/Jovanović 1968, Tab. 1. 5.

<sup>10</sup> Popović 2005, 158.

specimens more carefully manufactured and with sharply cut edges (Pl. 2, 2-3)<sup>11</sup>. Besides the mentioned slab all other specimens are fragmented and they were probably of more or less similar sizes corresponding to the upper parts (Pl. 3, 4-6).

Type C. The rotatory hand mill was the new technological invention and with further improvements it did not change for centuries<sup>12</sup>. One considerably damaged fixed part with a hole for the axle has been found at Krševica by accident (diameter is approximately 25 cm, Pl. 4, 6). Second specimen is completely preserved. Both parts were lying next to each other in a layer with many remains of the oven floors that preceded the horizon with the building in the central zone of the acropolis<sup>13</sup>. On the basis of the stratigraphic data this layer is dated in the end of the 4<sup>th</sup> century BC at the latest (for precise dimensions and appearance see Fig. 3; Pl. 4, 5).

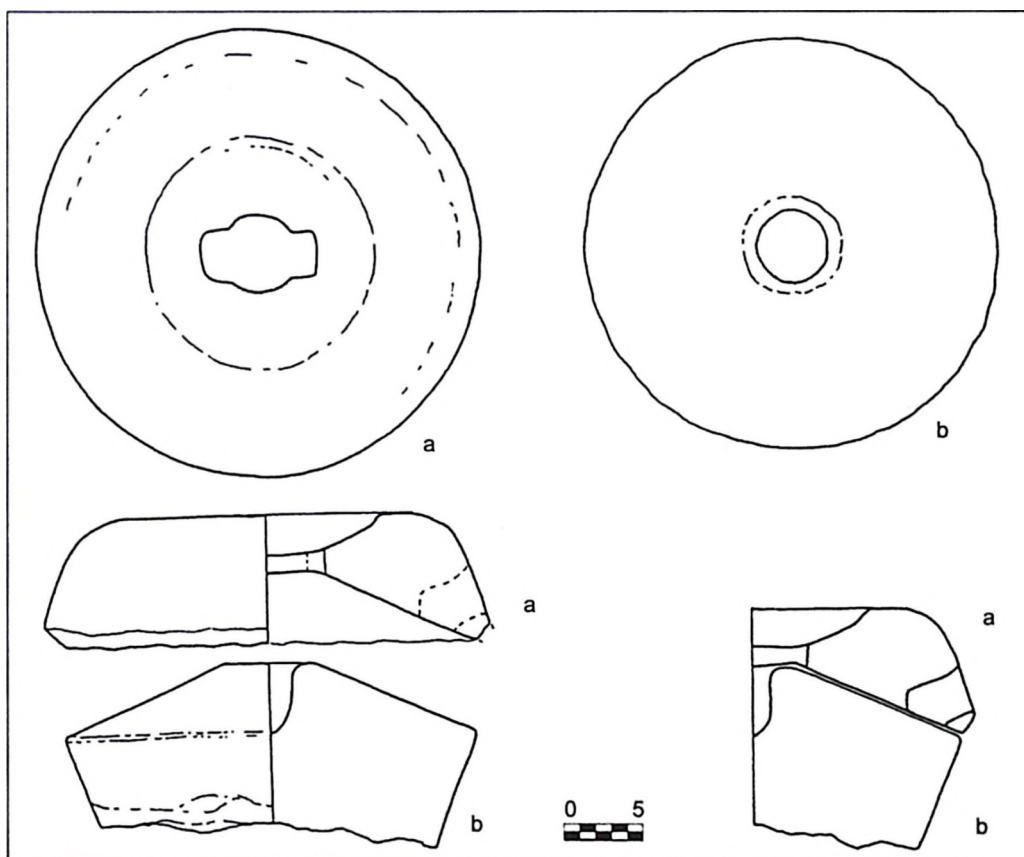

Fig. 3 *Hand rotatory mill in situ, acropolis, trench N 15-18, 2002*

<sup>11</sup> Ibid. Fig. 28.

<sup>12</sup> White 1963, 202 ff.

<sup>13</sup> Popović 2005, Fig. 29.

### 3. Composition and origin of stone

All the millstones from Krševica, with rare exceptions, were made of the volcanic stone of the basalt group because of its firmness and other essential characteristics. According to the microscopic analysis the basalt stone consists of phenocrystals: olivine, rhombic pyroxene, basic plagioclase, sphene and aphanitic basic mass. The texture is hollow with almond shaped elements, the structure is holocrystalline-porphyric to crystalline-porphyric (Pl. 4, 3-4)<sup>14</sup>.

It is very important in this case that the deposits of basalts were discovered in the course of geological investigations in the vicinity of Krševica in the nearby village Klinovac. There have also been registered the conspicuous traces of exploitation. Also, yet another quarry of this stone was discovered in the village Slavujevac near Preševo<sup>15</sup> and this reveals that the raw materials were at small distance from our site. Thanks to these resources the inhabitants of Krševica could have satisfied their basic needs within their settlement.

### 4. Main analogies

The mills of type B ('hopper rubber') have been encountered in the wider area of the Mediterranean so the problem of their origin and more detailed distribution exceeds by far the scope of our study. They have been found from the south France<sup>16</sup> and Spain, via Italy and Greece as far as the Near East<sup>17</sup> and the Black Sea coast<sup>18</sup>. It is considered that they followed the process of Greek colonization and thanks to intensive commercial contacts they spread towards the peripheral regions of the Mediterranean also penetrating deeply into the regions of the central Balkans. They are usually dated in the end of Classical and in the Hellenistic period and they gradually disappeared with the introduction of more modern types like the rotatory mills<sup>19</sup>.

It could be noticed at first glance that the method of working the volcanic stone to produce these mills varies in quality so there are specimens of quite symmetrical shapes made by the highly skilled craftsmen but there are also rather crudely shaped pieces of local provenance (Pl. 4, 1-2). It is obvious that there were workshops in the larger centers that produced these objects on order or they produced just the goods for the market. The good example

---

<sup>14</sup> Jovanović 2004.

<sup>15</sup> Ibid.

<sup>16</sup> Chaussairie-Laprée 2000, Fig. 8.

<sup>17</sup> Frankel 2003; Photo on Pl. 4, 2 was kindly provided by Nenad Lazarević archaeology student at the University of Belgrade.

<sup>18</sup> Coja/Dupont 1979, 53, Pl. 2, 94.

<sup>19</sup> White 1963, 202 ff.

is the well-known 'Kyrenia Ship' that sunk near Cyprus in the end of the 4<sup>th</sup> century BC. The ship load consisted of the amphorae with vine, almonds and high quality mills<sup>20</sup>. In any case, the mills were indispensable working implements in the areas with advanced agriculture and probably within each household was the area with a storeroom where the food was kept and probably the wheat was ground and perhaps the bread was also baked in the same place.<sup>21</sup> The distinct category of the ancient industry were *ergasteria*, the buildings where the ore was crushed and milled to a fine grain. The hopper querns and rotatory mills that could have been used for the ore but also for the wheat have been found in some of the rooms<sup>22</sup>. At Thasos, for instance, where the ore exploitation had been intensive it is assumed that massive mills were used for grinding ore but even here it could not be ruled out that their primary function was to grind wheat<sup>23</sup>.

Finds from Krševica are according to all their characteristic of local manufacture, which could be distinguished from similar specimens from northern Greece<sup>24</sup> or the neighboring parts of the Balkans on the basis of crude manufacture and less deep receptacles. Only few specimens from the site Isar in Marvinci<sup>25</sup> in the territory of FRY Macedonia have been published but the mills of this type must have been present in much larger quantity. Many mills have been found according to Prof. Dragi Mitrevski from the University of Skopje in the structures and houses at the site Vardarski Rid near Gevgelija (antique town of Gortynia) and similar results have also been obtained in the course of more recent investigations of the Hellenistic settlement at the site Glos near Valandovo. The absence of these finds in the Vardar valley and towards the central Balkans is a consequence of insufficiently published material and certainly does not offer real picture of their distribution. After all, publishing of the mills from Krševica is our attempt to give to these finds from the Central Balkans the place they deserve.

## 5. Conclusion

The investigations of the site Kale in Krševica revealed so far that an important settlement with urban characteristics that have close contacts with the Aegean during its entire life have been existing in the Južna Morava valley<sup>26</sup>. Thus the appearance of mills of the Mediterranean provenance was not a surprise for the investigators. In this case, however, it was not the

---

<sup>20</sup> Katzev 1974, 50, 63.

<sup>21</sup> Adam-Veleni 1998, 63, Pl. 40; cf. Frankel 2003, Fig. 6.

<sup>22</sup> Jones 1991, 108, Fig. 3.

<sup>23</sup> Muller 1979, 336 ff.

<sup>24</sup> Robinson/Graham 1938, 327 ff. (non vidi); Frankel 2003, 2 ff.

<sup>25</sup> Sokolovska 1986, 90, Tab. 38, 5-7. In contrast to Krševica specimens from this site are of larger size: 0.54 x 0.50 x 0.17 m; 0.59 x 0.52 x 0.16 m ; 0.54 x 0.52 x 0.12 m.

<sup>26</sup> Popović 2006, 528 ff.

question of imported goods but the mills were manufactured (carved) on the spot thanks to the deposits of volcanic stone in the immediate vicinity. Many common features including type of stone, method of manufacture, dimensions or rather shallow receptacle indicate that these are the local products and perhaps only few specimens are exceptions (Pl. 2, 2-3) particularly the rotatory mill (Pl. 4, 5). Something similar could be said, in a certain way, also for the large pottery production in Krševica. Namely, there is now sufficient evidence that there was a workshop, which produced the pottery after Greek models<sup>27</sup> to satisfy the needs of the inhabitants.

The investigations so far did not yield the conspicuous traces of the metallurgical activities and it means that mills were mainly used to grind the stored wheat when needed and to use it for bread making. This is best confirmed by many domed ovens discovered within the building horizons with structures on the acropolis as well as in the suburbium (Fig. 4)<sup>28</sup>. The fragments of shallow pans used for baking bread have been frequently found in the surrounding or in the immediate vicinity<sup>29</sup>. In addition to the cereals analyses revealed that great variety of domesticated and wild animals<sup>30</sup> supplemented to the diet of inhabitants and probably some Mediterranean foodstuff was also used. In brief, according to the diverse and abundant finds it is obvious that this settlement lived intensively during the 4<sup>th</sup> and in the first decades of the 3<sup>rd</sup> century BC and their remains in Krševica represent today the unique site in the heart of the Balkans.



Fig. 4 *Suburbium – hydrotechnical complex, oven, 2006*

<sup>27</sup> Popović 2005, 157 f.; 2006, 529, Fig. 11.

<sup>28</sup> Popović 2005, Fig. 8-9.

<sup>29</sup> Antić/Babić 2005, 216, Pl. 6, 7-8.

<sup>30</sup> Blažić 2005.



## Rezime

### Žrvnjevi iz Krševice (Jugoistočna Srbija)

Istraživanja lokaliteta Kale u Krševici kod Bujanovca (2001-2007) pokazala su da se u dolini Južne Morave nalaze značajni ostaci naselja s kraja klasičnog i početka helenističkog perioda koje je imalo urbane odlike i za sve vreme postojanja održavalo bliske veze s Egejom (Sl. 1). Na osnovu nalaza importovane keramike iz atičkih i severnoegejskih radionica, datovane u raspon od početka IV do prvih decenija III veka pre n. e., dobijeni su i osnovni hronološki okviri života u ovom naselju. Najviše arheološkog materijala, međutim, čini lokalna keramika rađena po grčkim uzorima. To je široki repertoar oblika koji obuhvata kako stone posude, tako i razno kuhinjsko posuđe, lonce i pitose velikih dimenzija koji su služili za pripremanje i skladišćenje hrane. Kako je reč o organizovanom naselju, ishrana stanovnika imala je veliki značaj, što se odnosi i na izvestan broj nalaza koji su prikazani u ovom radu.

Reč je o većem broju uglavnom fragmentovanih žrvnjeva od vulkanskog kamena koji su otkriveni na prostoru od akropole do podgrađa i imali osnovnu namenu da se mlevenjem žita obezbedi brašno za pravljenje hleba. Većinu čine primerci s pravougaonim recipijentom i pločom (tip B – Tab. 1, 3-4; 2-3), dok malobrojni žrvnjevi odgovaraju najstarijim (tip A – Tab. 1, 1-2), ili savremenijim oblicima (tip C – Sl. 3, Tab. 4, 5-6). Karakteristični su za Mediteranski prostor i prema svim odlikama nalazi iz Krevice su lokalnog porekla. To objašnjava činjenica da su ležišta bazalta iz neposredne blizine omogućila redovno snabdevanje i izradu žrvnjeva za potrebe naselja. Često su nađeni u blizini objekata i na mestima gde su otkrivene peći s kalotom i delovi plitkih činija koje su korišćene za pečenje hleba (Fig. 4). Pored ovih osnovnih namirnica mnogobrojni drugi nalazi svedoče o raznovrsnoj ishrani stanovnika i intenzivnom životu u naselju tokom IV i prvih decenija III veka pre n. e.

## Bibliography

- Adam-Veleni, P.* 1998, Petres of Florina, Thessaloniki 1998.
- Antić, I./Babić, S.* 2005, Preliminarni rezultati tipološko-statističke obrade keramičkog materijala sa lokaliteta Kale – Krševica (Preliminary Results of Typological and Statistic Analyses of Pottery from the Site Kale – Krševica), Zbornik Narodnog muzeja XVIII-1, Beograd 2005, 213-227.
- Antonović, D.* 2003, Neolitska industrija glačanog kamena u Srbiji (Neolithic Ground Stone Industry in Serbia), Arheološki institut, posebno izdanje 37, Beograd 2003.

- Blažić, S.* 2005, Fauna lokaliteta Kale – Krševica (Fauna from the Site Kale in Krševica), Zbornik Narodnog muzeja XVIII-1, Beograd 2005, 263-290.
- Bulatović, A.* 2005, Keramika brnjičke kulturne grupe i starijeg gvozdenog doba sa nalazišta Kale u Krševici (Pottery of the Brnjica Culture and of Early Iron Age from the Site Kale in Krševica), Zbornik Narodnog muzeja XVIII-1, Beograd 2005, 175-190.
- Chaussarie-Laprée, J.* (ed.) 2000, Le temps des Gaulois en Provence, Martigues 2000.
- Coja, M. / Dupont, P.* 1979, Ateliers céramique, Histria V, 1979.
- Frankel, R.* 2003, The Olynthus Mill, Its Origin, and Diffusion: Typology and Distribution, American Journal of Archaeology 107. 1, 2003, 1-21.
- Jones, E.* 1991, The Planning and Construction of Attic *Ergasteria*. In: Hoffmann, A./Schwandner, E.-L./Hoepfner, W./Brands, G. (eds.), Bautechnik der Antike, Verlag Philipp von Zabern – Mainz am Rhein, 1991.
- Jovanović, M.* 2004, Tercijarne bazaltoidne stene u Srbiji. Rudarsko geološki fakultet – katedra za petrologiju. Univerzitet u Beogradu (unpublished PhD thesis)
- Katzev, M.* 1974, The Kyrenia Ship. In: Bass F. G. (ed.), A History of Seafaring, Omega 1974, 50-64.
- Krstić, V.* 2005, Slikani kantarosi i skifosi sa lokaliteta Kale – Krševica kod Bujanovca (Painted Kantharoi and Skyphoi from Kale – Krševica), Zbornik Narodnog muzeja XVIII-1, Beograd 2005, 191-211.
- Mikulčić, I. / Jovanović, M.* 1968, Helenistički oppidum iz Krševice kod Vranja (Oppidum hellénistique de Krševica près de Vranje), Vranjski glasnik IV, Vranje 1968, 355-375.
- Muller, A.* 1979, Le mine de l'acropole de Thasos, Thasiaca, Bulletin de correspondance hellénique Suppl. V, 1979, 315-344.
- Popović, P.* 2005, Kale – Krševica: Investigations 2001-2004. Interim Report, Zbornik Narodnog muzeja XVIII-1, Beograd 2005, 141-174.
- Popović, P.* 2006, Central Balkans between the Greek and Celtic World: Case Study Kale Krševica. In: N. Tasić/C. Grozdanov (eds.), Homage to Milutin Garašanin, Beograd 523-536.
- Popović, P.* 2007, Nakit iz Krševice (The jewellery from Krševica). In: Blečić, M. / Črešnar, M. / Hänsel, B. / Hellmuth, A. / Kaiser, E. / Metzner-Nebelsick, C. (eds.), Scripta praehistorica in honorem Biba Teržan, Situla 44, Ljubljana 813-820.
- Robinson, D. M. / Graham A. J. W.* 1938, Excavations at Olynthus VIII: The Hellenistic Houses, Baltimore 1938.
- Sokolovska, V.* 1986, Isar-Marvinci, Skopje 1986.
- Vanderpool, E. / McKredie, J. / Steinberg, A.* 1962, Koroni: A Ptolemaic Camp of the East Coast of Attica, Hesperia XXXI. 1, 1962, 26-61.
- White, D.* 1963, A Survey of Millstones from Morgantina, American Journal of Archaeology 67. 2, 1963, 199-206.

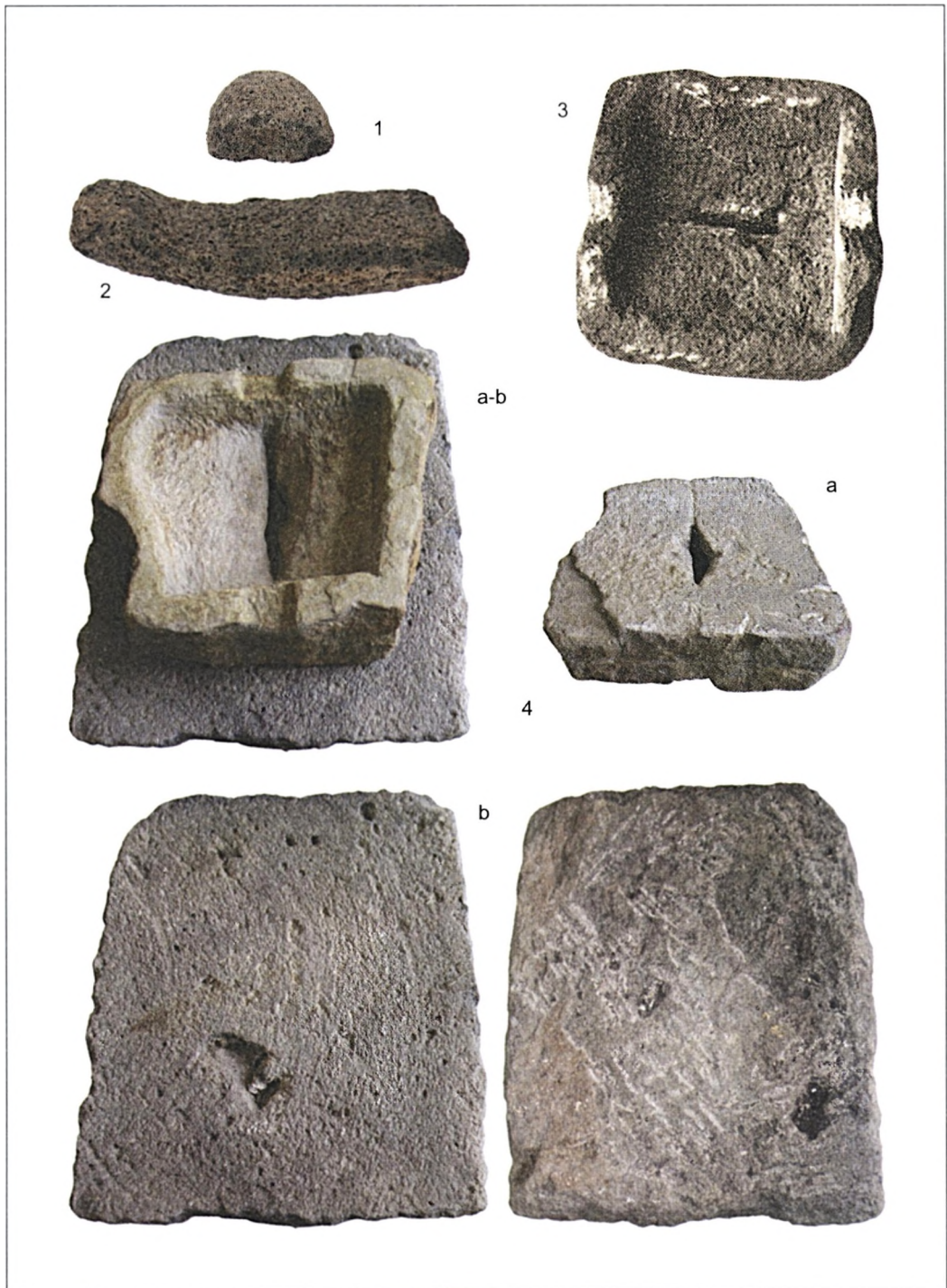

Pl. 1. 1-2 mills of type A; 3-4 mills of type B  
(3. after Mikulčić / Jovanović 1968, Tab. 1.5)

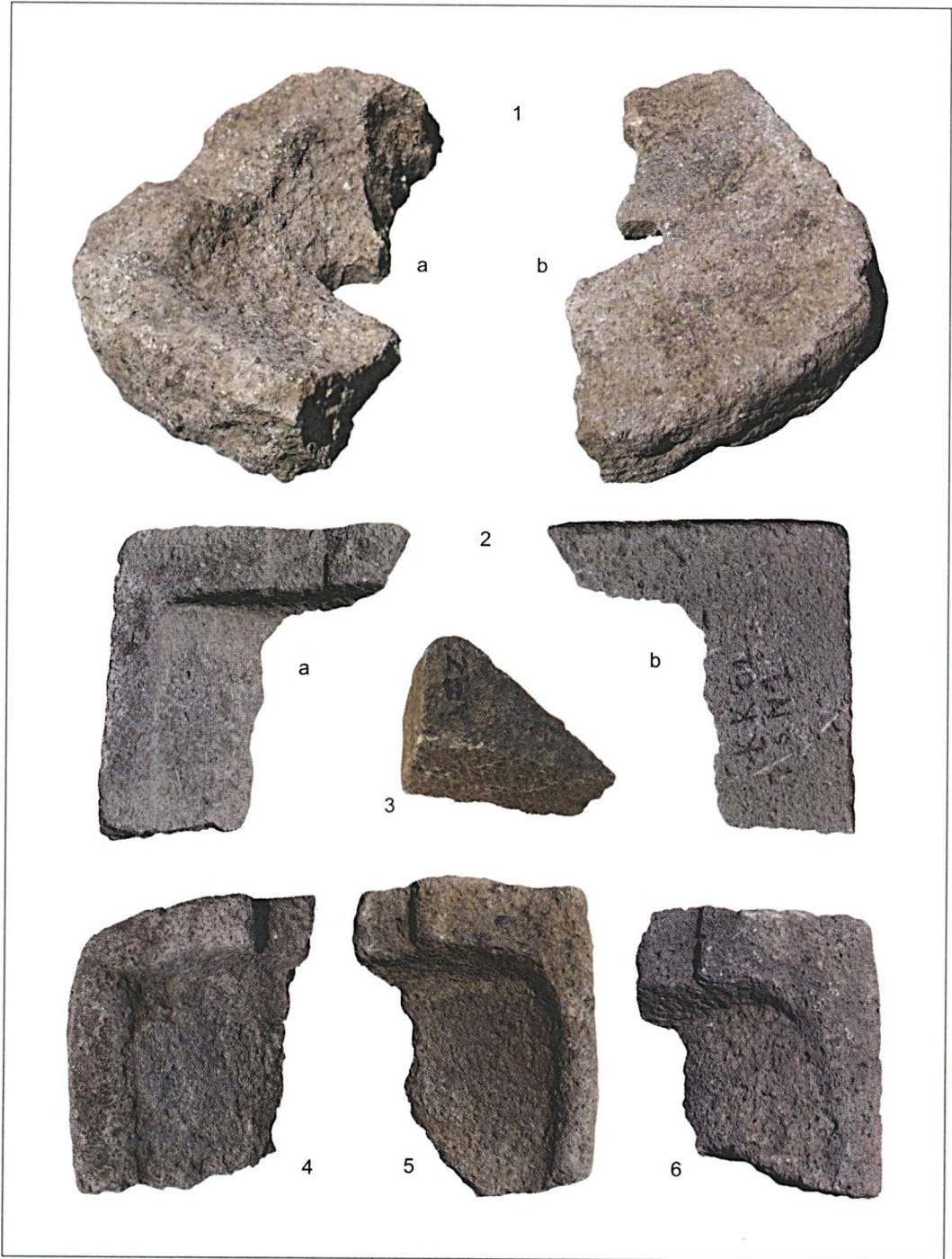

Pl. 2. 1-6 Mills of type B



Pl. 3. 1-6 *Mills of type B*



Pl. 4. *Mills of type B*: 1. *Koroni, Attica*, dim. 0.35 x 0.45 x 0.13 m (after Vanderpool et al. 1962, Pl. 22. 33); 2. *Museum in Idlib, Syria*;  
 3. 4 detail and section (x 50); 5. 6 – *mills of type C*